

Veritas® Grinder Tool Rest

(05M23.01)

Most bench grinders come with small and flimsy tool rests that make accurate grinding nearly impossible. The Veritas® Grinder Tool Rest provides a large stable surface that is infinitely adjustable for accurate grinding on 6" or 8" bench grinders and many belt sanders, and can be readily folded out of the way for freehand grinding. Spring-loaded gyratory handles lock it solidly in position and can be rotated out of the way after locking. The Angle-Setting Gauge allows you to set the Grinder Tool Rest to grind to one of four common bevel angles (see below).

Mounting the Table:

The base of the Grinder Tool Rest has two slots to accept 1/4" carriage bolts for fixing it to the bench in front of your grinder. Wing nuts below the bench will make it easy to remove or adjust the Grinder Tool Rest without tools.

Drill two 5/16" diameter holes 1-1/8" apart through your grinding bench, approximately 2" from the front of the grinder base and directly in front of the grinding wheel. Fix the Grinder Tool Rest to the bench with two 1/4" carriage bolts, washers, and wing nuts (not included). Before tightening the nuts, be sure that the Grinder Tool Rest is square to the grindstone, with the slot centered on it. (This is not critical, but helps when using grinding jigs fitted in the table slot.)

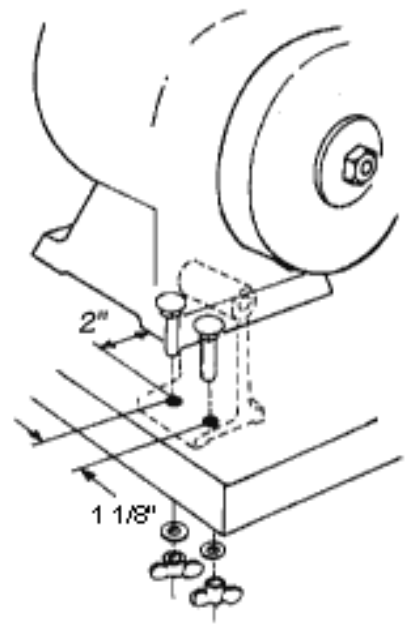

Jigs and Fixtures:

The table is milled with a 1/2" x 1/2" groove to accept the Veritas® Grinding Jig as well as a 1/4" hole for the Veritas® Skew-Grinding Jig. You can make your own custom jigs to slide in the groove or pivot in the hole to suit your own particular needs.

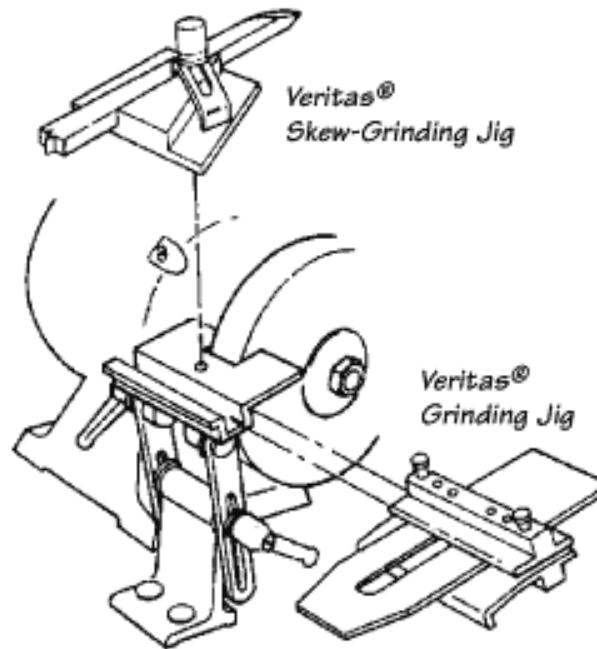

Safety:

Always wear safety glasses when working on a grinder.

When freehand grinding, adjust the position of the Grinder Tool

Rest so that there is no more than 1/8" of clearance between the table and the grinding wheel. Don't adjust the table when the grinder is running.

Veritas® Angle-Setting Gauge

The Angle-Setting Gauge allows you to quickly set your Grinder Tool Rest to grind one of four common bevel angles. When grinding on a wheel, the bevel of a ground chisel is concave, not flat and the angle is approximate. This angle is also related to the diameter of your grinding wheel, which changes over time as your wheel gets smaller.

Setting a particular angle benefits you when you transfer your chisel or plane blade to a stone for honing; it allows you to set your honing guide to a specific angle and will speed the process of sharpening as you will have removed the bulk of material during grinding.

Checking the blade angle and thickness

If you wish to duplicate the existing angle on a blade, you can use the gauge to check this in one of two ways. On the shallow side of the gauge, there is a circular depression in the center; you can place the chisel face on the reference edges running into the circle and check it against each of the four angles that are marked (Figure 1). Alternatively, for more registration, you can place the gauge on a flat surface and check the blade under each angular face with the bevel butted up to the gauge (Figure 2).

You also need to know how thick the blade is to properly set the Grinder Tool Rest to your wheel. Place the blade on a reference edge running into the center circle, and note how many lines thick the blade is; most plane blades will be about one line thick, and most chisels will be less than two. This height is important because the angle gauge must touch the stone at $\frac{1}{2}$ of the thickness of the blade in order to correctly set the angle (Figure 3).

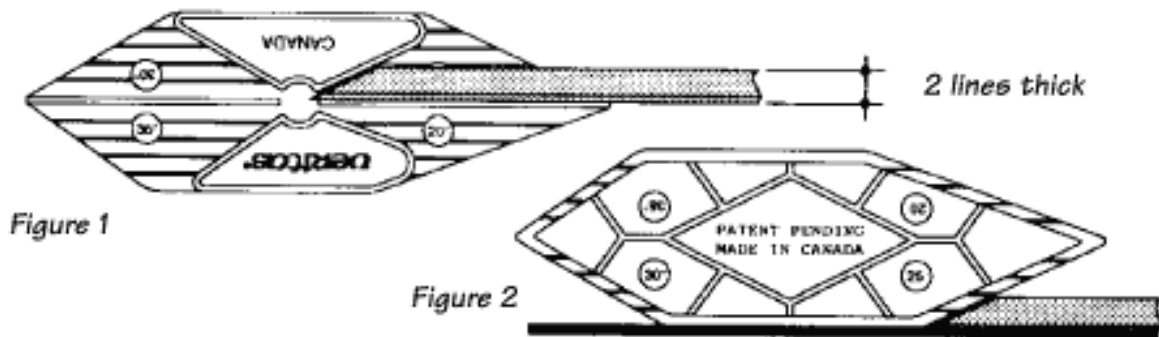

Setting the tool rest angle

Both faces of the Angle-Setting Gauge have horizontal lines spaced $\frac{1}{8}$ " apart. In order to correctly set the angle of your tool rest, you need to place the angle gauge flat on the table of your tool rest with the selected bevel angle face down, and extending towards the wheel face. Tilt the tool rest table so that the wheel contacts the gauge at $\frac{1}{2}$ the thickness of the blade or chisel that you just measured in the steps above (Figure 3).

You will soon find that all this is much easier than it sounds.

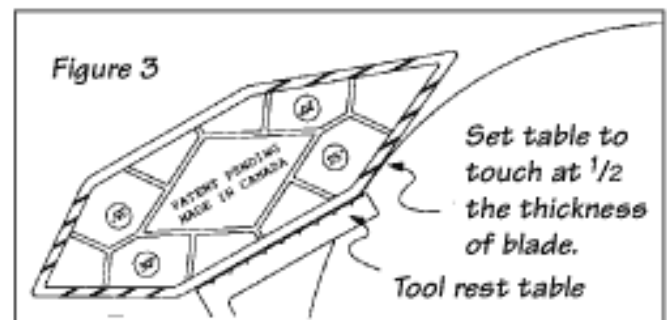

You will also find that minor errors in estimating blade thickness are not critical.

Setting angles for use with your Veritas® Grinding Jig

When you use the Veritas® Grinding Jig in conjunction with the Grinder Tool Rest, you are elevating the blade or chisel from the reference (table) surface. In order to properly use the Angle-Setting Gauge, you must measure the thickness of the blade or chisel, determine how many lines $1/2$ the thickness is, and add one more line to accommodate for the thickness of the Grinding Jig.

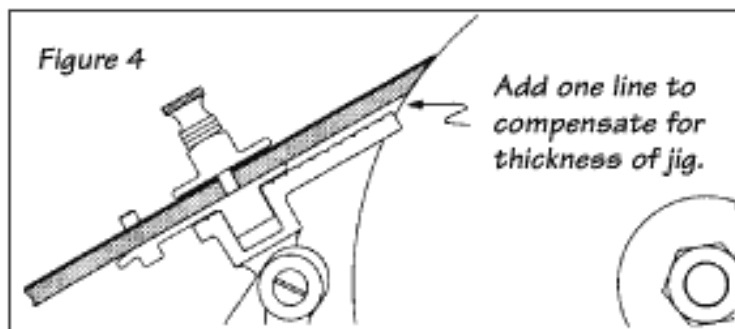

Simply remember to add one line thickness after you have determined where the Angle-Setting Gauge should touch the wheel (Figure 4).